

M O R N I N G

MORNING MINI MM530

USER MANUAL

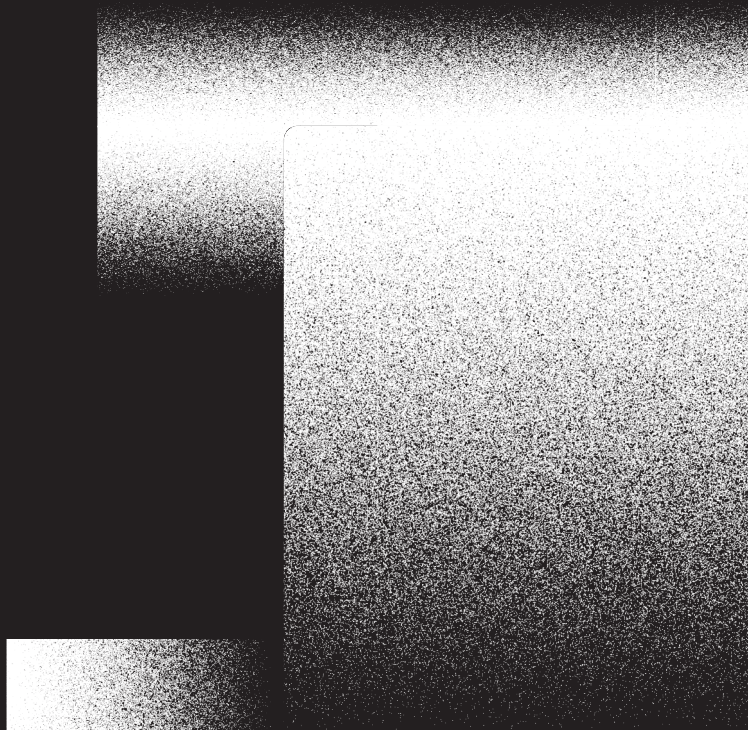

CONTENTS

| | |
|----|------------------------------------|
| 4 | Safety Precautions |
| 7 | What's in the Box |
| 8 | Machine Overview |
| 9 | Machine Dial |
| 10 | Setting Up Your Machine |
| 11 | Priming the Machine |
| 12 | Brewing Your First Cup |
| 14 | Purging After Use |
| 15 | Recipe List |
| 16 | Compatible Capsule Types |
| 17 | Brewing Tips |
| 18 | Pairing with the Morning App |
| 19 | Steps on How to Pair |
| 20 | Brewing with Roaster Recipes |
| 21 | Creating Your Own Recipe |
| 22 | ECO Mode and Resetting the Machine |
| 23 | Cleaning and Maintenance |
| 25 | Troubleshooting |
| 26 | Technical Specifications |
| 27 | Warranty Information |

SAFETY PRECAUTIONS

General Safety Precautions

- This product may become hazardous if these instructions and safety precautions are ignored.
- In an emergency, unplug from the power socket immediately.
- This product is for household use only. The manufacturer accepts no responsibility for commercial use, inappropriate use, or non-compliance with instructions.

Safe Usage Guidelines

- Unplug and let the product cool before cleaning. Never clean with a wet cloth or immerse the plug, cord, or product in liquids.
- Children aged 8 and above can use the product with supervision and if they understand the hazards.
- Cleaning and maintenance should not be done by children aged 8 and below unless supervised. Keep the product and cord out of their reach.
- People with reduced physical, sensory, or mental capabilities can use this product if supervised or instructed on safe use and hazards.
- Children should not play with the product.

Specific Usage Precautions

- Always use the drip tray and drip grid.
- Keep the product/cord out of children's reach.
- Do not fill the water tank with hot water.
- Do not immerse the product in liquid to avoid electrocution.
- Only use compatible capsules. If a capsule doesn't fit, do not force it.

Electrical Safety

- Ensure the voltage on the rating plate matches your supply.
- Connect only to earthed sockets; improper connection voids the warranty.
- Unplug if not in use for a long time.
- Keep the power cord away from hot surfaces and sharp objects.
- Never touch the cord with wet hands.
- Unplug by holding the plug, not the cord.
- Do not hang the unit by the cord to prevent tripping. If the cord is damaged, do not use the product.
- Only Morning should repair the product and replace the power cord to avoid hazards.

Maintenance and Handling

- Do not open the product or insert objects into openings.
- Only Morning should perform actions beyond regular use, cleaning, and care. Unauthorised maintenance voids the warranty.
- Do not use the product if damaged or not in perfect condition. Inform Morning if damaged.
- Place on a flat, stable, heat-resistant surface away from water and heat sources.

Environmental and Disposal Considerations

- Packaging materials (plastic bags, etc.) are recyclable but can be hazardous. Keep them away from children.
- Do not dispose of this product with household waste in the EU. Recycle responsibly to prevent environmental harm and promote the sustainable reuse of materials.

Additional Safety Tips

- Do not splash liquids onto the machine. If spilled, unplug immediately.
- Intended for household use and similar environments: staff kitchens, offices, hotels, motels, and bed and breakfast environments.
- Never leave the product unattended during use.
- Do not use if damaged or malfunctioning. Unplug and contact Morning or authorised representatives for repair or adjustment.
- A damaged product can cause electrical shocks, burns, and fire.
- Always close the lever completely. Do not lift it during use to avoid scalding.
- Do not put fingers under the coffee and water outlet to avoid scalding.
- Water around an unperforated capsule can damage the product.
- Do not use already used, damaged, or deformed capsules.
- If a capsule is blocked, turn off and unplug the machine before any operation. Contact Morning or authorised representatives.
- Always use fresh drinking water in the water tank.
- Empty the water tank if not used for an extended period (e.g., holidays).
- Replace the water if the product has not been operated for more than a week.
- Use the drip tray unless using a tall mug/cup to avoid spills.
- Use a damp cloth and mild cleaner. Do not use strong cleaning agents or solvents.
- Remove and dispose of the plastic film when unpacking.
- Morning reserves the right to change instructions without prior notice.

RESTRICTION OF HAZARDOUS SUBSTANCES IN ELECTRICAL AND ELECTRONIC EQUIPMENT (ROHS)

| RoHs | Pb | Hg | Cd | Cr(VI) | PBBs | PBDEs |
|---|----|----|----|--------|------|-------|
| Plastic enclosure and chassis | ✓ | ✓ | ✓ | ✓ | ✓ | ✓ |
| Motors and valves | ✓ | ✓ | ✓ | ✓ | ✓ | ✓ |
| Printed circuit board assembly | ✓ | ✓ | ✓ | ✓ | ✓ | ✓ |
| Cables and wires | ✓ | ✓ | ✓ | ✓ | ✓ | ✓ |
| Heating module and other metal components | ✓ | ✓ | ✓ | ✓ | ✓ | ✓ |

✓ RoHS 3 (EU 2015/863) compliant

WHAT'S IN THE BOX

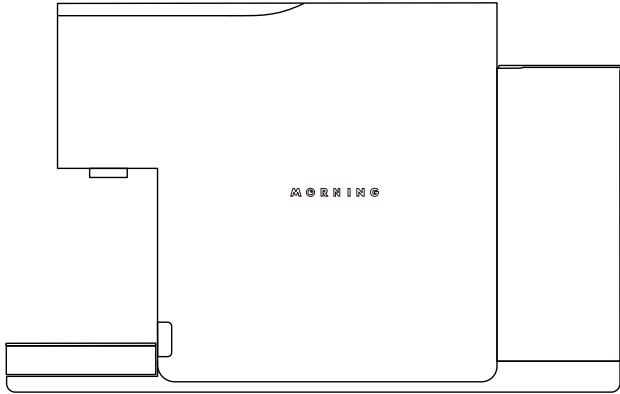

The Morning Mini

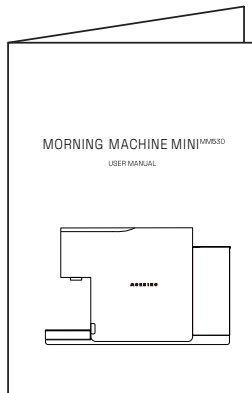

User Manual





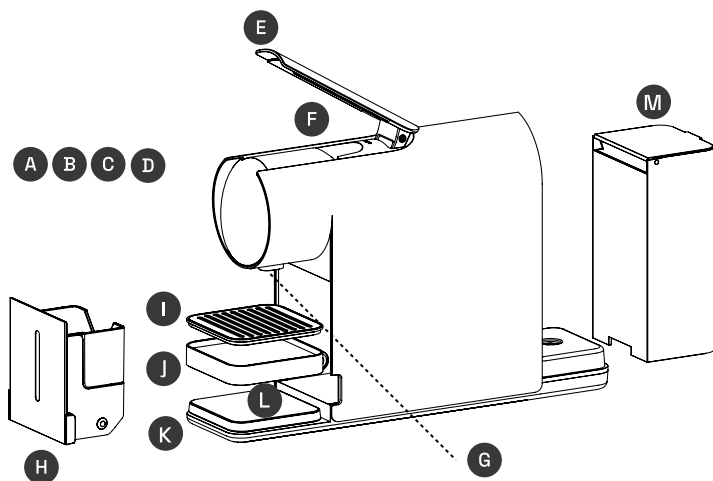

MACHINE OVERVIEW

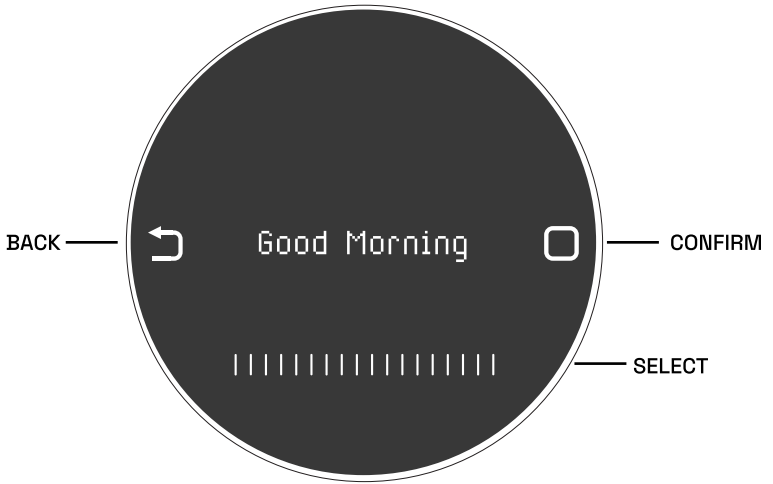
- A Dial Control
- B OLED Screen
- C Back button
- D Confirm button
- E Lever
- F Capsule Slot
- G Coffee Outlet
- H Capsule Bin
- I Drip Tray Cover
- J Drip Tray
- K Silicone Tray
- L Scale
- M Water Tank



MACHINE DIAL



| FUNCTION | BUTTON |
|------------------|---|
| Confirm / Next |  Confirm button |
| Back / Cancel |  Back button |
| Scroll |  Swipe left or right |
| Purge |  Press and hold for 3 seconds |
| Press any button | Wake machine |
| Settings |   Press and hold both buttons |

SETTING UP YOUR MACHINE

WARNING: IMPORTANT SAFETY INFORMATION

- **Voltage Check:** Before use, verify that the power supply voltage corresponds with the voltage specified on the Morning Machine's packaging and rating plate.
- **Packaging Retention:** Preserve the original packaging for safe transport of the Morning Machine if relocation is needed in the future.
- **Residual Water Notice:** It is normal to discover a negligible quantity of water inside the Morning Machine. This is a result of the quality assurance tests conducted at our manufacturing facility.
- **Electrical Hazard Warning:** Handling electrical equipment improperly poses a significant risk and may lead to severe injury or death. Adhere strictly to the safety instructions provided in this manual to prevent any accidents.

1. **Positioning Your Machine:** Place the Morning Machine on a stable, flat surface, such as your kitchen countertop, to ensure safety and proper operation.
2. **Preparing the Components:** If the Morning Machine has not been in use recently, remove the water tank and drip base to give them a quick rinse. Ensure a thorough cleansing to maintain optimal machine performance.
3. **Filling the Water Tank:** Add fresh filtered water to the water tank up to the indicated MAX line. Avoid operating the machine without water to prevent damage. The tank can hold up to a maximum of 700ml.
4. **Installing the Water Tank:** Gently slide the water tank back into its base on the machine. You should notice a 'click' as it locks into place, signifying secure attachment.
5. **Power Connection:** Connect the Morning Machine to the main power source or outlet. Ensure that the power specifications match those required by the machine.
6. **Machine Activation:** Upon successful connection to the power source, the Morning Machine will power on automatically.
7. **Priming the Machine:** For the initial use, or if the machine has not been operated for an extended period, it is crucial to prime the machine before brewing. This step ensures that the internal system is prepared for optimal brewing performance.

PRIMING THE MACHINE

If this is your first use or if you have not used the machine for a prolonged period, please prime the machine before by following these steps:

1. Place an empty cup (at least 100ml capacity) under the machine.
2. Ensure that the water tank is full.
3. Ensure that there is not capsule in the chamber.
4. Press and hold the BACK button to purge the machine.
5. Repeat the process until water comes out of the coffee spout.

CALIBRATING THE SCALE

To recalibrate the machine's scale, perform the following steps:

1. Go to machine settings.
2. Select Calibration.
3. Select Scale Zero.
4. Empty the scale and press CONFIRM
5. Select Scale Rating and press CONFIRM
6. Wait for the Success message to complete the calibration.

BREWING YOUR FIRST CUP

Here's how to brew using the Morning Mini's 5 ready-to-brew recipes.

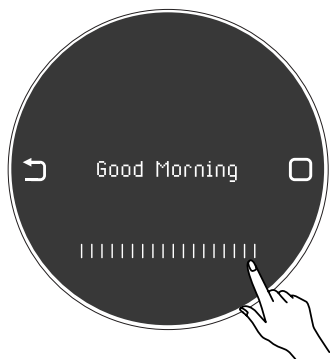

STEP 1

Turn on the Morning Mini by plugging it into a power outlet. Wake the machine up by pressing any of the two buttons on the dial.

STEP 2

Lift the lever completely and insert the coffee capsule.

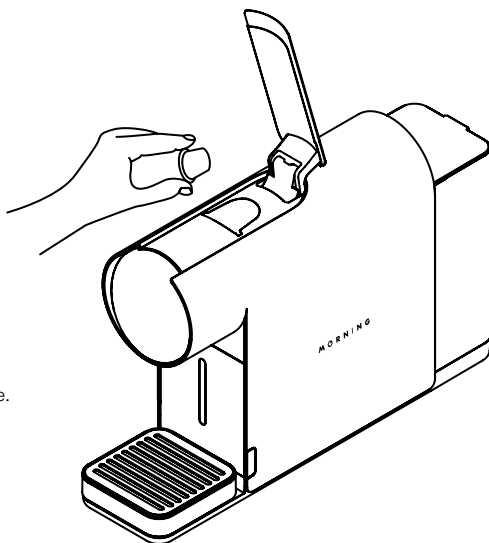

STEP 3

Close the lever and place your cup on the drip tray.
If you are using a taller cup, remove the drip tray and place the mug on the scale.

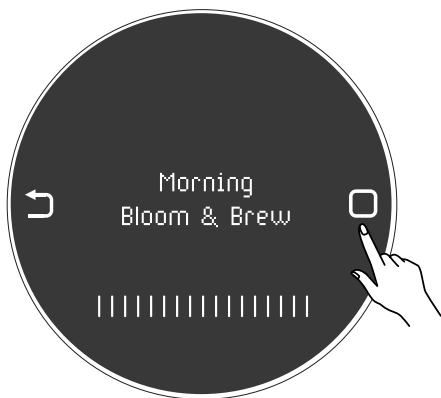
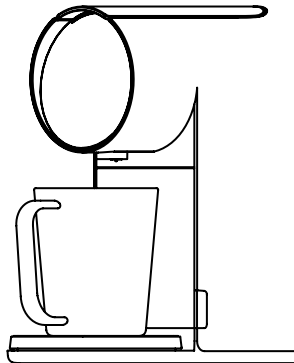
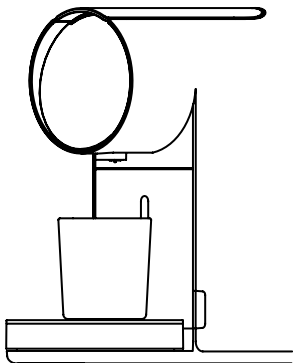

STEP 4

Select a recipe from our Ready-To-Brew recipes. Press CONFIRM to start the brewing process.

PURGING AFTER USE



STEP 5

The Morning Mini will heat water based on temperature setting of the recipe. The brewing process will commence and a progress meter will appear until brewing is complete.

STEP 6

After the brew, remove the cup and lift the lever to eject the coffee capsule from the brewing chamber into the capsule bin.

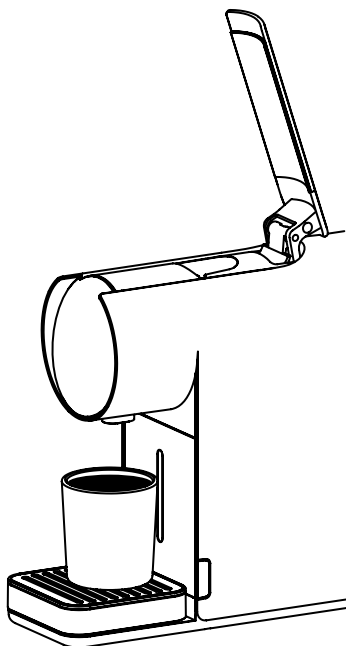

RECIPE LIST

| Recipe | Description | Coffee Output* |
|------------------|---|----------------|
| Bloom & Brew | Morning's flagship recipe, with a built-in Bloom stage (pre-wet/infusion) before the brew. There will be a 30-second pause during the Bloom stage. This brews a stronger cup of coffee. | 30g |
| Short Dark Roast | A recipe for short, espresso-style coffees. This recipe is suitable for coffees which are medium-dark roasted. These coffees tend to have a syrupy mouthfeel. | 30g |
| Long Dark Roast | A recipe for a long black coffee, suitable for coffees which are medium-dark roasted. Use this recipe if the capsule is indicated to be enjoyed as a lungo or long coffee. | 80g |
| Classic | The most versatile coffee recipe to brew coffees from different origins or roast styles. Literally, it's the perfect shot of coffee. | 40g |
| Ceremony | Inspired by the Ethiopian Coffee Ceremony, this recipe is in between an espresso and a lungo-type beverage. Perfect for medium to light-roasted coffees. | 80g |

*Recipe outputs are subject to change.

COMPATIBLE CAPSULES

The Morning Machine is designed to be compatible with Nespresso® OriginalLine capsules as well as third-party compatible capsules. It supports the use of Aluminium and Compostable coffee capsules.

Since compostable capsules may change shape due to the heat during brewing, we recommend ejecting the capsule immediately after the brewing process to prevent it from getting stuck in the chamber.

BREWING TIPS

TIP #1

Shaking the coffee capsule before use ensures an even distribution of the coffee grounds inside. This allows the machine to extract the coffee's full potential.



TIP #2

Press and hold the BACK button for 3 seconds to run water through the machine. This helps warm up the machine and clean the brew unit, ensuring the best cup of coffee possible.

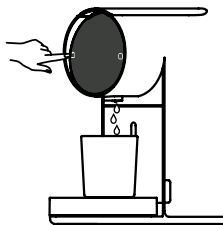

TIP #3

Use filtered water with the Morning Mini. Filtered water significantly reduces limescale buildup. By using filtered water, you can extend the lifespan of your Morning Mini, maintain optimal performance, and ensure a cleaner, better-tasting cup of coffee every time.

TIP #4

If you found a recipe that you enjoy, save it to the machine for easy brewing. Brew, drink, repeat.

TIP #5

The Bloom & Brew function can be applied to any recipe you create via the Morning App.

PAIRING WITH THE MORNING APP

Pair your Morning Mini with the Morning App to enjoy all its features.

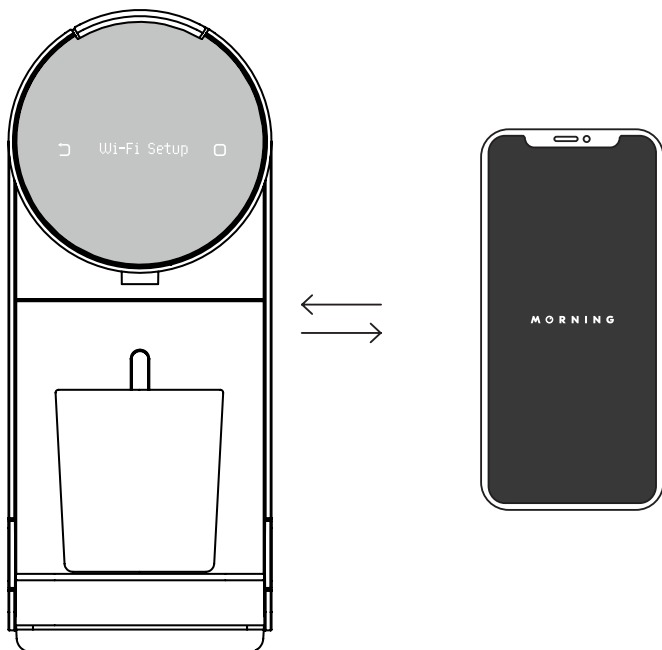

- You will need to connect the machine to a Wi-Fi source with an active internet connection.
- Turn on Bluetooth on your device before proceeding.

STEPS ON HOW TO PAIR



1. Download the Morning App from the Apple App Store or the Google Play Store. Search for "DrinkMorning".
2. Check that your phone's Bluetooth is switched on, then launch the Morning App.
3. On your machine, enter the Settings by holding down both the BACK and CONFIRM buttons.
4. Enter the Settings page, then toggle the dial to Set Up Wi-Fi and press the CONFIRM button.
5. The machine will display "Configure On App".
6. Back on the Morning App, select the "My Machine" icon on the top left. Select "Add New".
7. Follow the steps on the Morning App to pair your machine.
8. Once the pairing process is complete, machine will display "Setup Complete".

BREWING WITH ROASTER RECIPES

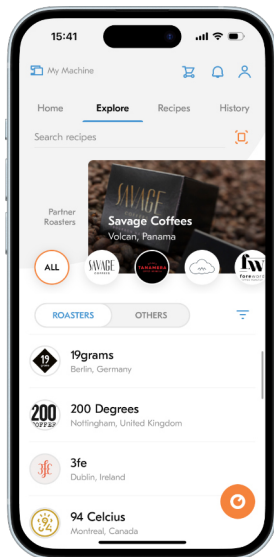

The Morning Mobile app provides users with access to a database of partner roasters and a growing list of compatible coffee capsules, including Nespresso® OriginalLine and third-party options.

To brew a cup of coffee using a Roaster recipe, first navigate to the desired Roaster on the Morning App and select a recipe. Then, press the “Start Brewing” button to begin brewing the selected recipe.

Save up to 5 recipes on the Morning Mini by selecting the (...) at the top followed by “Save to Machine”.

CREATING YOUR OWN RECIPE



With the Morning App, you can create custom recipes that suit your preferences. You can save your recipes on the machine or on the app for convenient brewing.

Open the Morning Mobile app on your smartphone, then click the Brew tab to create your recipes.

Save up to 5 recipes on the Morning Mini by selecting the (...) at the top followed by "Save to Machine".

ECO MODE

The Morning Machine includes an Eco Mode feature designed to save energy. After 10 minutes of inactivity, the machine will automatically switch to Eco Mode. To reactivate the machine, simply scroll the dial or tap any on-screen button.

To customize the Eco Mode timing, adjust the settings in the machine's Settings menu.

RESETTING THE MACHINE

To reset the machine, perform the following steps:

1. Press and hold both BACK and CONFIRM buttons > SETTINGS.
2. Select Restore Factory Settings.
3. Press the CONFIRM button.

When you reset the machine, the following happens:

1. All your created recipes are deleted from the Machine.
2. All default recipes gets reloaded into the Machine.
3. The Wi-Fi connection settings are removed.

CLEANING AND MAINTENANCE

WARNING: IMPORTANT SAFETY INFORMATION

- **Water Exposure:** Under no circumstances should the Morning Mini or any of its components be submerged in water. This can lead to electrical hazards and damage to the machine.
- **Power Safety:** Always disconnect the Morning Mini from the power source before initiating any cleaning procedures. This precaution is necessary to prevent electric shock or damage to the machine.
- **Cleaning Agents:** Refrain from using any harsh or solvent-based cleaning agents when cleaning the Morning Mini. Such substances can cause irreparable damage to the surface and internal components.
- **Abrasive Tools:** Avoid the use of sharp objects, stiff brushes, or any kind of abrasive material that could scratch or damage the surface of the Morning Mini.
- **Dishwasher Usage:** The Morning Mini is not designed to be dishwasher-safe. Placing the machine or any of its parts in a dishwasher could result in damage and is strictly prohibited.

DAILY CLEANING

We recommend emptying the capsule container and drip tray and the drip tray every day.

1. Raise the lever to ensure that there is no capsule inside the chamber.
2. Remove the drip tray from its position.
3. Remove the capsule container and the drip base.
4. Rinse both with fresh water.
5. Remove the water tank and rinse under fresh water.
6. Dry all the parts with a fresh and clean towel, cloth or paper towel.
7. Clean the Coffee Outlet and the Water By-pass Outlet regularly with a damp cloth.

DEEP CLEANING (MONTHLY)

We recommend using cleaners like the Cafetto Eco Capsule Clean at least once a month, depending on your usage. This process reduces the risk of machine faults that can occur as a result of blockages.

1. Insert 1 cleaning capsule into the machine and close the lever.
2. Ensure that the water tank is full of water with an empty cup under the coffee outlet.
3. Press both BACK and CONFIRM buttons > MAINTENANCE on the machine.
4. Run the "Basic Clean Cycle" procedure and follow on-screen instructions.
5. Lift the lever to eject the cleaning capsule into the capsule bin when the cleaning cycle is complete.
6. Follow the on-screen instructions for the rinse cycle.

DESCALING (YEARLY)

We recommend descaling the machine at least once a year. You may use existing descaling products in the market, such as the Cafetto Renew Descaler.

1. Fill the water tank with water up to 0.5L.
2. Add 1 sachet of your descaling agent into the water tank.
3. Remove the drip tray and place a large cup under the coffee outlet.
4. Press both BACK and CONFIRM buttons > MAINTENANCE on the machine.
5. Run the Guided Descaling procedure follow on-screen instructions.
6. If you need to refill the water tank during the process, fill until the MAX level.
7. Should you need to pause the descaling process to empty the cup, press the BACK button at any time.

TROUBLESHOOTING

| PROBLEM | POSSIBLE CAUSE | SOLUTION |
|--|---|--|
| No coffee is brewed. | The water tank is empty. | Fill the water tank with water to the MAX level. |
| Spent capsule did not drop down after raising the lever. | The capsule bin is full. | Empty the capsule bin |
| | The spent capsule is deformed after brewing. | Use a teaspoon to remove the stuck capsule from the brew chamber. Do not use a sharp object. The brew chamber may leak if damaged or scratched. |
| There is steam when the lever is raised. | The lever is raised too quickly after brewing. | Let the residual pressure escape for a few seconds before raising the lever. |
| There is water on the countertop. | The water tank is leaking. | Check the valve in the water tank to ensure that it is not stuck when removed. Check if the tank is seated fully in place in the Machine. |
| | The drip tray is full. | Empty the drip tray. |
| The coffee is not hot enough. | Cup or mug might be cold. | Pre-heat your cup or mug. |
| | Low temperature set for the recipe | Set the ideal brew temperature for your recipe. |
| | Scale build-up in the Machine. | Perform the descaling procedure. |
| The coffee outlet is dripping water even after brewing. | The heater is being kept warm. | This is normal behaviour. |
| Coffee comes out in drips from the coffee outlet. | The ground coffee inside the capsule might be too fine for water to pass. | Roasters vary their grind sizes depending on their coffee beans and roast profiles. Smaller grind sizes that cause drip-like flow in the machine is acceptable. |
| The machine is running but no coffee is coming out. | There may be air bubbles present in the water pipes of the machine. | On your Machine, make sure your water tank is full and that there are no capsules in the brew chamber. Then press and hold the BACK button to perform a purge. Repeat this process until water comes out from the coffee outlet. |
| Check for Blockage warning message. | | |

TECHNICAL SPECIFICATIONS

| | |
|---------------------------|--|
| Size and weight | 365mm (L) x 95mm (W) x 235mm (H), 4.5kg |
| Water tank capacity | 600ml |
| Maximum cup height | 30mm (with drip tray), 19mm (without drip tray) |
| Capsule bin capacity | 4-5 capsules |
| OLED screen size | 2.23 inches |
| OLED resolution | 128 x 64 pixels |
| Touch buttons | 2 capacitive buttons and a touch slider interface 50mm x 8mm |
| Electrical specifications | AC220-240V 50-60Hz 1200-1300W; AC220V 60Hz 1200W; AC120V 60Hz 1250W; AC100V 50/60Hz 1250W |
| Pump specifications | 20 bar, 230V 50Hz; 20 bar, 220V 60Hz; 20 bar, 120V 60Hz; 20 bar, 100V 50/60Hz |
| Maximum pump pressure | 20 bar |
| Pressure control | 3 stages, 7 levels |
| Coffee output control | 1g - 250g in 1g increments |
| Temperature control | 75°C - 98°C, in 1°C increments |
| Connectivity | Wi-Fi and Bluetooth |
| Capsule compatibility | Nespresso® OriginalLine capsules and third-party compatible capsules |
| Software requirements | iOS (version 10.0 and later), Android (version 5.0 and later) |

WARRANTY INFORMATION

Morning warrants this product against defects in materials and workmanship for a period of 1 year (2 years in EU countries) from the date of purchase. Official receipts shall serve as proof of purchase.

During this period, Morning will either repair or replace, at its discretion, any defective product at no charge to the owner. Replacement products or repaired parts will be guaranteed for only the unexpired portion of the original warranty or six months, whichever is greater.

This limited warranty does not apply to any defect resulting from accident, misuse, or any other reason beyond Morning's reasonable control, including but not limited to: normal wear and tear, negligence or failure to follow the product instructions, improper or inadequate maintenance, calcium deposits or descaling, connection to improper power supply, unauthorised product modification or repair, use for commercial purposes, fire, lightning, flood or other external causes.

This warranty is valid only in the country of purchase or in such other countries where Morning sells or services the product. This limited warranty shall be the full extent of Morning's liability however caused.

Except to the extent allowed by applicable law, the terms of this limited warranty do not exclude, restrict or modify the mandatory statutory rights applicable to the sale of this product and are in addition to those rights.

If you believe your product is defective, please reach out to us at hello@drinkmorning.com for instructions on where to send or bring it for repair.

