

M O R N I N G

MORNING DREAM MD630

USER MANUAL

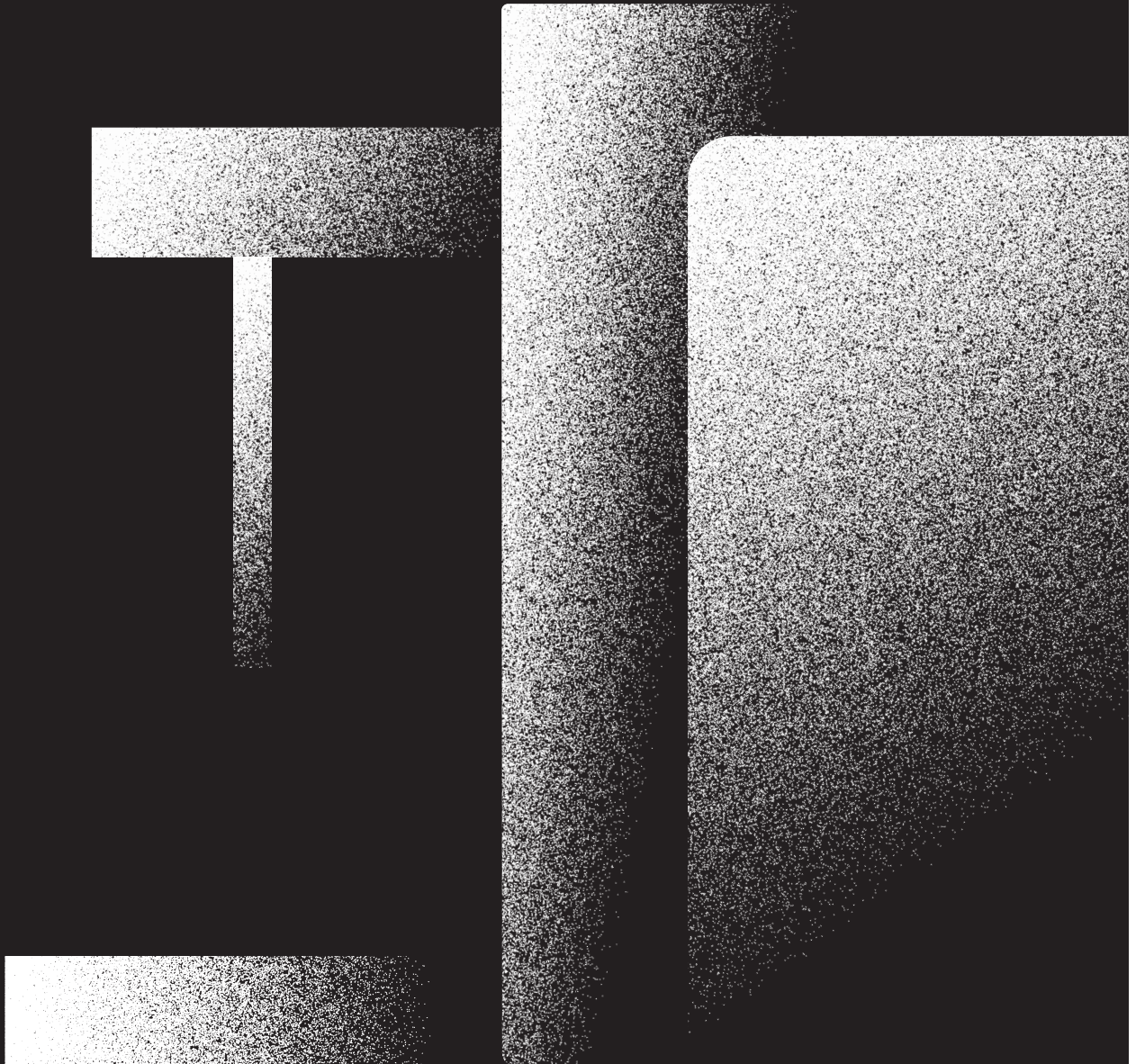

CONTENTS

4	Safety Precautions
7	What's in the Box
8	Machine Overview
9	Machine Dial
10	Key Indications
11	Setting Up Your Machine
12	Steaming Your First Cup of Milk
15	Purging After Use
17	Manual Mode
18	Pairing with the Morning Application
21	Cleaning and Maintenance
23	Troubleshooting
24	Technical Specifications
25	Warranty Information

SAFETY PRECAUTIONS

GENERAL SAFETY PRECAUTIONS

- This product may become a safety hazard if these instructions and safety precautions are ignored.
- In the event of an emergency, immediately remove the plug from the power socket.
- This product is intended for household and similar use only. The manufacturer accepts no responsibility, and the guarantee will not apply in the event of any commercial use, inappropriate use, or failure to comply with the instructions.

SAFE USAGE GUIDELINES

- Before cleaning, unplug the product and let it cool down. Never clean with a wet cloth or immerse the plug, cord, or product in any liquids.
- This product can be used by children aged 8 years and above if they have been given supervision or instruction concerning the product's safe use and if they understand the hazards involved.
- Cleaning and user maintenance shall not be made by children aged 8 years and above unless supervised. Keep the product and the power cord out of reach of children aged less than 8 years.
- This product can be used by people with reduced physical, sensory, or mental capabilities. Inexperienced and under-knowledgeable people are allowed if they have been given supervision or instruction concerning the safe use of the product and understand the hazards involved.

SPECIFIC USAGE PRECAUTIONS

- Do not touch the steam wand and metal nozzle, as there is a risk of scalding.
- Do not use the product without the drip tray and drip grid.
- Keep the product/cord out of reach of children.
- Do not fill the water tank with hot water.
- Do not immerse the machine in liquid as there is a risk of electrocution.
- To avoid the risk of injury, do not touch the steam nozzle during the steam emission process.

ELECTRICAL SAFETY

- Check that the voltage quoted on the rating plate is the same as your voltage.
- Connect the product to earthed power sockets only. An improper connection voids the warranty.
- Remove the plug from the socket if not in use for a long time.
- Do not place the power cord near hot parts or sharp objects, etc.
- Never touch the cord with wet hands.
- Do not unplug by pulling the cord.
- Do not hang the unit by the power cord as there is a danger of tripping. If it is damaged, do not use the product.
- To avoid any hazards, only allow Morning to repair the product and replace the power cord.

MAINTENANCE AND HANDLING

- Do not attempt to open the product or insert anything into the openings.
- All actions other than regular use, cleaning, and care must be performed by Morning. Unauthorised maintenance will void warranty.
- Do not use the product if it is not in perfect working condition or evidence of damage. In such cases, inform Morning.
- Place on a flat, stable, and heat-resistant work surface away from water splashes and any heat sources.

ENVIRONMENTAL AND DISPOSAL CONSIDERATIONS

- Packaging materials (plastic bags, etc.) are recyclable and potential hazards. Keep them out of reach of children.
- This product should not be disposed of with other household wastes throughout the EU. To prevent possible harm to the environment or human health from uncontrolled waste disposal, recycle it responsibly to promote the sustainable reuse of material resources.

ADDITIONAL SAFETY TIPS

- It is strongly suggested that the Machine be placed evenly on a stable, secure, and heat-resistant surface.
- Children shall not play with the appliance.
- Do not splash liquids onto the machine. If liquids have been spilled on the machine, please immediately cut off the power and unplug it.
- This appliance is intended to be used in household and similar applications such as staff kitchen areas in shops, offices, and other working environments; farmhouses; by clients in hotels, motels, and other residential-type environments; bed and breakfast-type environments.
- Never leave the product unattended during operation.
- Do not use the product if it is damaged, has been dropped, or not operating correctly. Immediately remove the plug from the power socket. Contact Morning or Morning-authorized representatives for examination, repair, or adjustment.
- A damaged product can cause electrical shocks, burns, and fire.
- Do not put fingers under the steam nozzle, as there is a risk of scalding.
- Always fill the water tank with fresh drinking water.
- Empty the water tank if the product will not be used for an extended time (holidays, etc).
- Replace water in the water tank when the product is not operated for more than a week.
- Do not use the product without the drip tray unless using a tall mug/cup to avoid spilling any liquid on surrounding surfaces.
- Do not use any strong cleaning agent or solvent cleaner. Use a damp cloth and mild cleaning agent to clean the surface of the product.
- When unpacking the Machine, remove and dispose of the plastic film.
- Morning reserves the right to change instructions without prior notice.

RESTRICTION OF HAZARDOUS SUBSTANCES IN ELECTRICAL AND ELECTRONIC EQUIPMENT (ROHS)

RoHs	Pb	Hg	Cd	Cr(VI)	PBBs	PBDEs
Plastic enclosure and chassis	✓	✓	✓	✓	✓	✓
Motors and valves	✓	✓	✓	✓	✓	✓
Printed circuit board assembly	✓	✓	✓	✓	✓	✓
Cables and wires	✓	✓	✓	✓	✓	✓
Heating module and other metal components	✓	✓	✓	✓	✓	✓

✓ RoHS 3 (EU 015/863) compliant

WHAT'S IN THE BOX

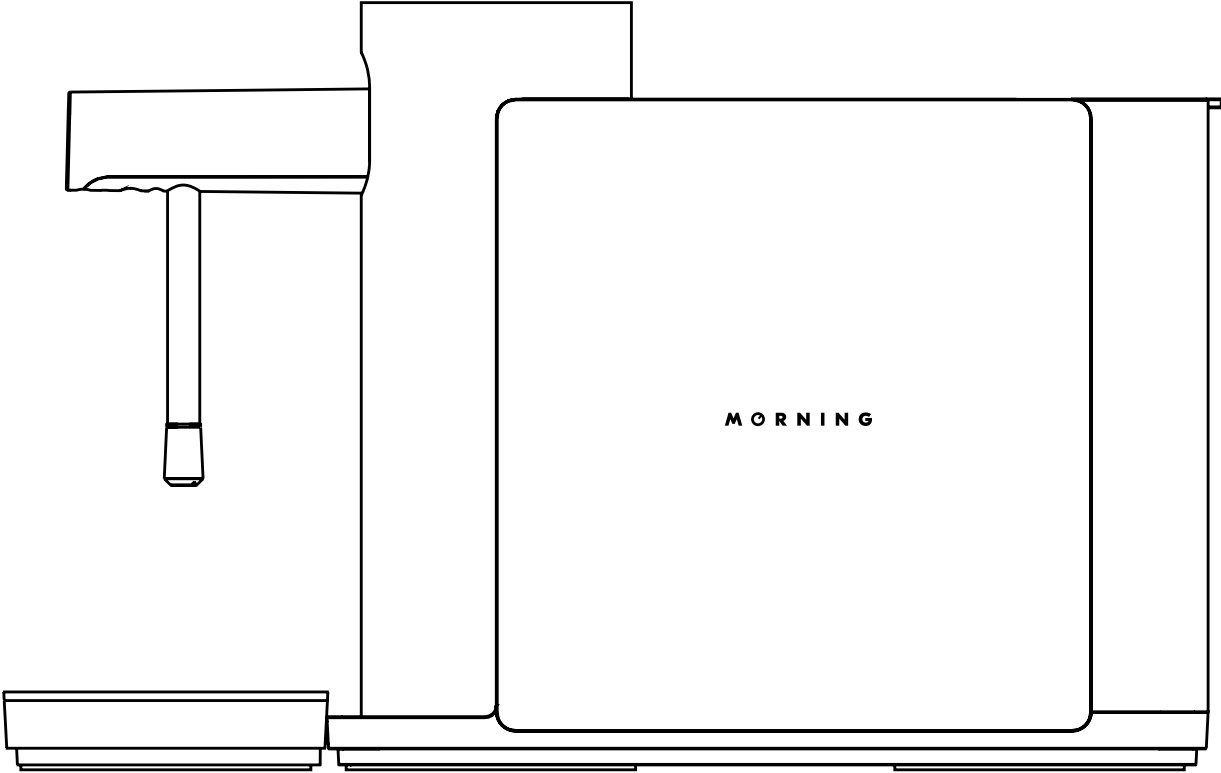

The Morning Dream

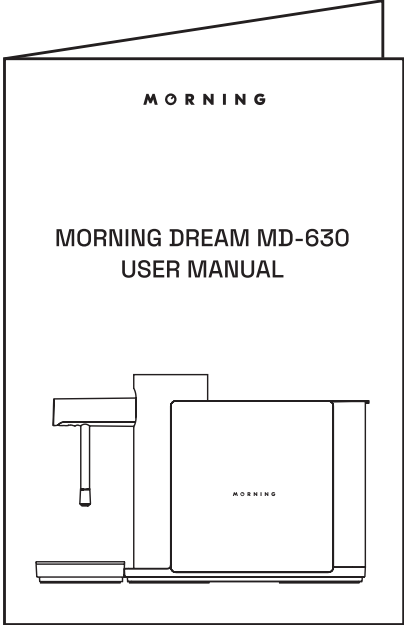

User Manual





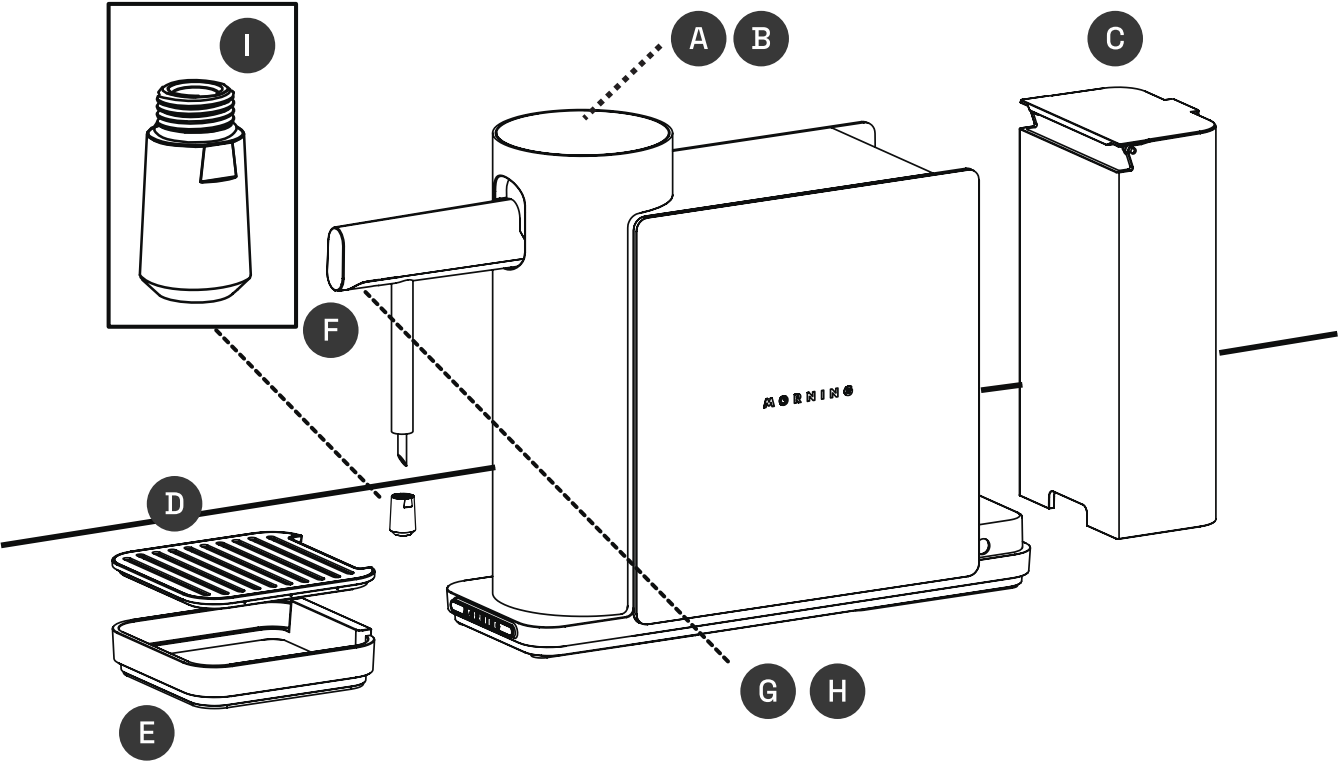

MACHINE OVERVIEW

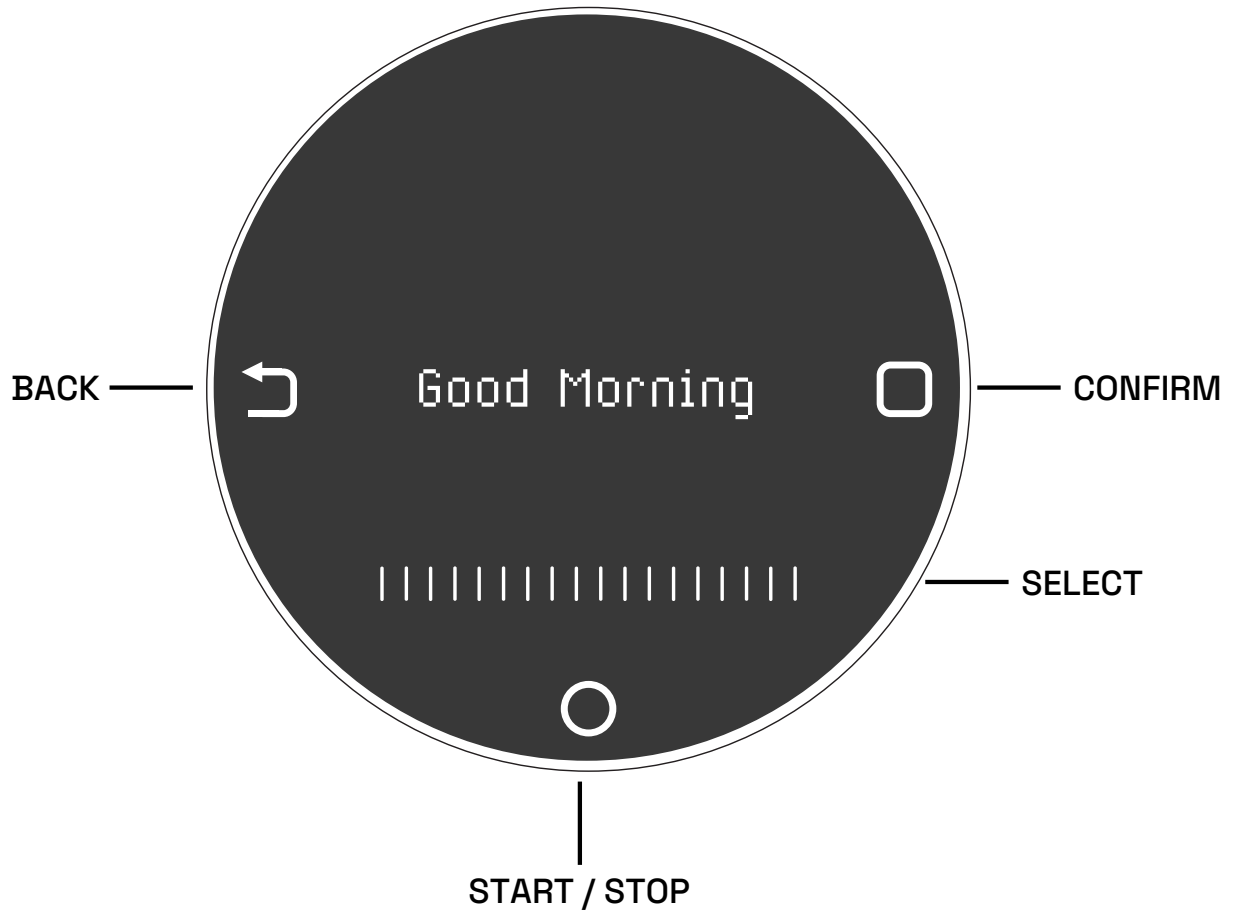
- A** Dial Control
- B** OLED Screen
- C** Water Tank
- D** Drip Tray Cover
- E** Drip Tray
- F** Arm
- G** Infrared Temperature Sensor
- H** Infrared Laser
- I** Steam Nozzle



MACHINE DIAL



FUNCTION	BUTTON
Confirm	 Confirm button
Back/Cancel	 Back button
Scrolling	 Swipe left or right
Start/Stop	 Start button
Purge	 Press and hold for 3 seconds
Settings	  Press and hold both buttons

SETTING UP YOUR MACHINE

WARNING: IMPORTANT SAFETY INFORMATION

- **Voltage Check:** Before use, verify that the power supply voltage corresponds with the voltage specified on the Morning Machine's packaging and rating plate.
- **Packaging Retention:** Preserve the original packaging for safe transport of the Morning Machine if relocation is needed in the future.
- **Residual Water Notice:** It is normal to discover a negligible quantity of water inside the Morning Machine. This is a result of the quality assurance tests conducted at our manufacturing facility.
- **Electrical Hazard Warning:** Handling electrical equipment improperly poses a significant risk and may lead to severe injury or death. Adhere strictly to the safety instructions provided in this manual to prevent any accidents.

1. **Positioning Your Machine:** Place the Morning Machine on a stable, flat surface, such as your kitchen countertop, to ensure safety and proper operation.
2. **Preparing the Components:** If the Morning Machine has not been in use recently, remove the water tank and drip base to give them a quick rinse. Ensure a thorough cleansing to maintain optimal machine performance.
3. **Filling the Water Tank:** Add fresh filtered water to the water tank up to the indicated MAX line. Avoid operating the machine without water to prevent damage. The tank can hold up to a maximum of 600ml.
4. **Installing the Water Tank:** Gently slide the water tank back into its base on the machine. You should notice a 'click' as it locks into place, signifying secure attachment.
5. **Power Connection:** Connect the Morning Machine to the main power source or outlet. Ensure that the power specifications match those required by the machine.
6. **Machine Activation:** Upon successful connection to the power source, the Morning Machine will power on automatically.
7. **Priming the Machine:** For the initial use, or if the machine has not been operated for an extended period, it is crucial to prime the machine before brewing. This step ensures that the internal system is prepared for optimal brewing performance.

PRIMING THE MACHINE

1. **Water Tank Check:** Confirm that the water tank is completely filled to ensure there is enough water to generate steam.
2. **Container Preparation:** Take a handheld container or cup with a capacity of at least 300 ml that has a handle for safety. Angle the steam nozzle downward and submerge it fully into the container or cup.
3. **Activating Water Flow:** Firmly press and continue to hold the 'BACK' button. This action will allow water to flow into the machine's pipeline, priming it for steam production.
4. **Steam Generation:** Continue the above process until you observe steam being emitted from the steam nozzle. This indicates that the machine is properly primed and ready for use.

STEAMING YOUR FIRST CUP OF MILK

The Morning Dream has 3 preset steaming modes, each tailored to complement different types of milk (whole, low fat and alternative milks). For those who enjoy customising their steaming profiles, the machine also offers a manual mode where the steaming parameters can be adjusted.

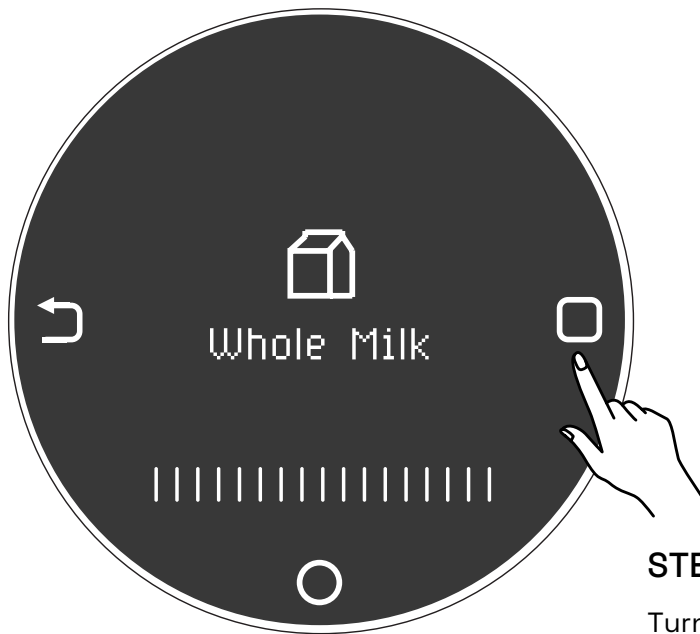

STEP 1

Turn on the Morning Dream by plugging it into a power outlet. Wake the machine by pressing the CONFIRM button.



STEP 2

Select a preset mode via the slider.

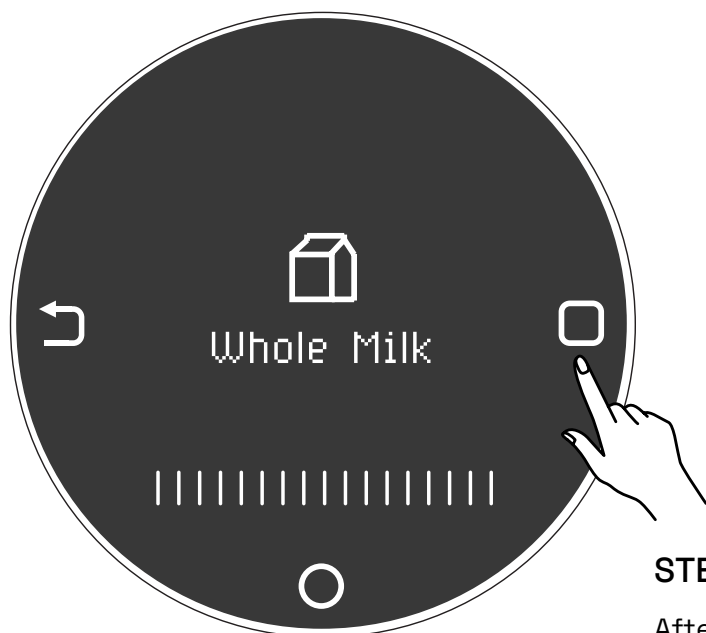

STEP 3

After selecting the desired preset mode, press the CONFIRM button.

PRESET MODES

NAME	DESCRIPTION	TARGET MILK TEMPERATURE	STEAM POWER SETTING
Whole Milk	Used for whole milk	62°C	75%
Low Fat Milk	Used for low fat milk	60°C	85%
Alternative Milk	Used for alternative milk, such as oat or almond milk	58°C	65%
Manual	Set the target temperature and steam power setting	40-75°C	50-100%

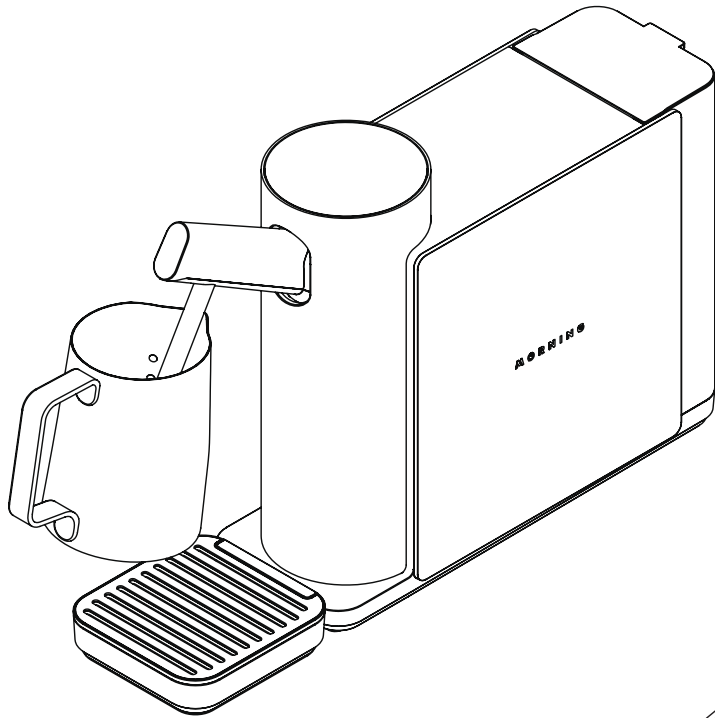

STEP 4

Place the steam wand into the jug containing milk.

STEP 5

Press the START button to initiate steam application. When the target temperature is reached, the Morning Dream will stop automatically. You may then remove your jug.

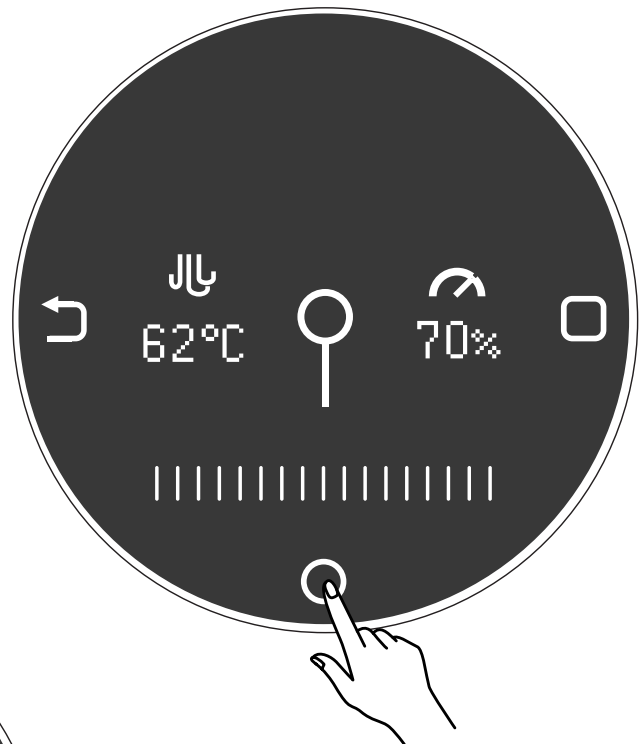

STEP 6

The screen will display a vortex animation while steam is being applied. The animation will stop when the steam process is complete.

PURGING AFTER USE

STEP 1

Remove the jug, point the steam wand vertically down, and cover it with a heat-resistant wiping cloth.

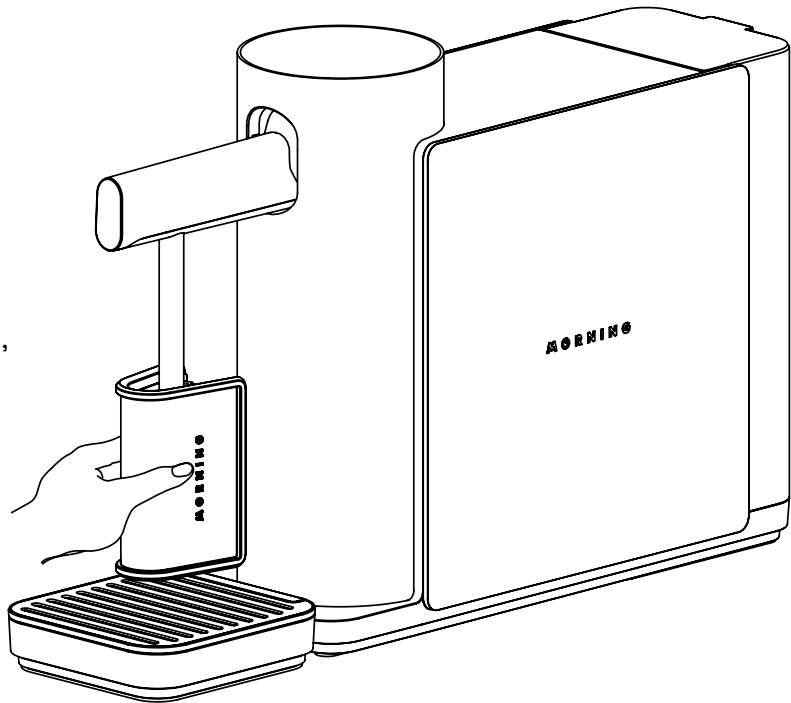

STEP 2

Ensure that the steam head is completely covered by the heat-resistant wiping cloth, then press the START button to initiate the purge process. Move the wiping cloth to wipe the steam wand as steam is being applied.

CAUTION!!

Do not remove the heat-resistant wiping cloth while steam is being applied to avoid getting scalded.

EDITING THE PRESET MODES

The preset steaming modes can be edited using the following steps:

1. Go to either recipe.
2. Press both the **BACK** and **CONFIRM** buttons simultaneously to enter the preset mode editor.
3. Use the **BACK** and **CONFIRM** buttons to toggle between temperature and power selection.
4. When ready, press the **CONFIRM** button. The display will then show "Finish Editing?".
5. Press the **CONFIRM** button again to complete.

MANUAL MODE



STEP 1

Select Manual Mode via the slider and press the CONFIRM button.

STEP 2

Select the desired milk temperature using the slider. Press the CONFIRM button to switch to the steam pressure selection.

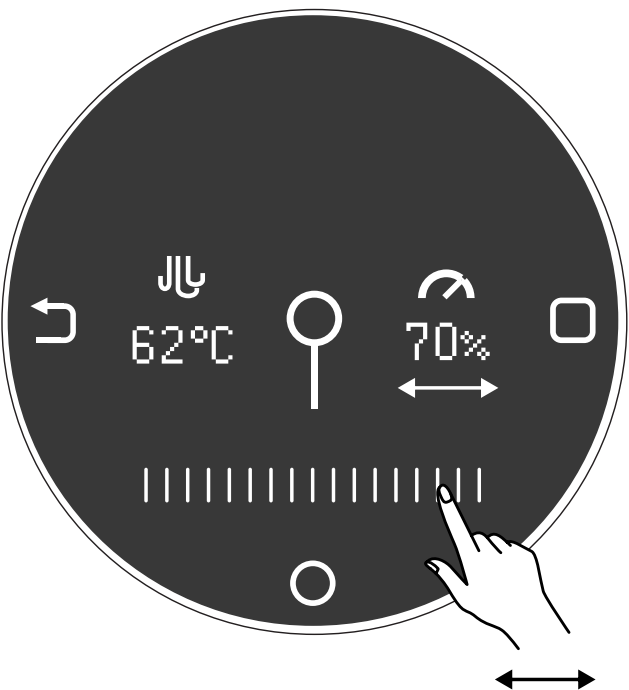
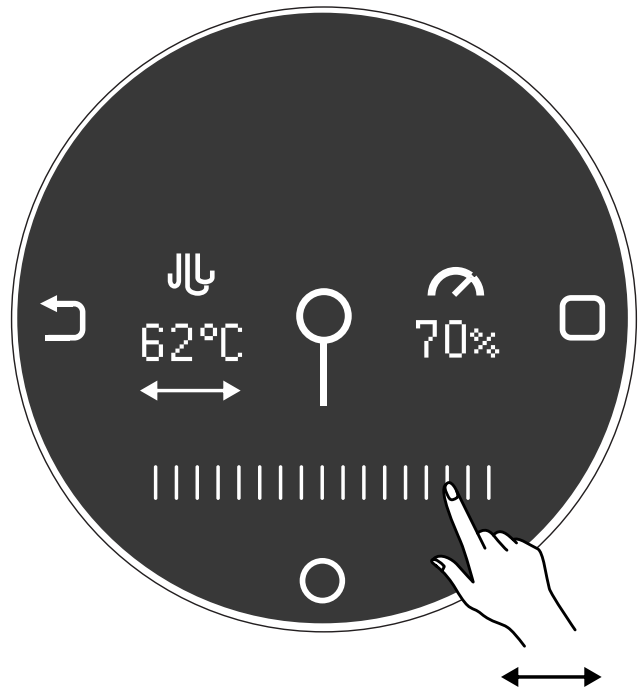

STEP 3

Select the desired steam pressure using the slider. Press the CONFIRM button to switch back to temperature selection.

PAIRING WITH THE MORNING APP

Pair your Morning Dream with the Morning App to enjoy all its features.

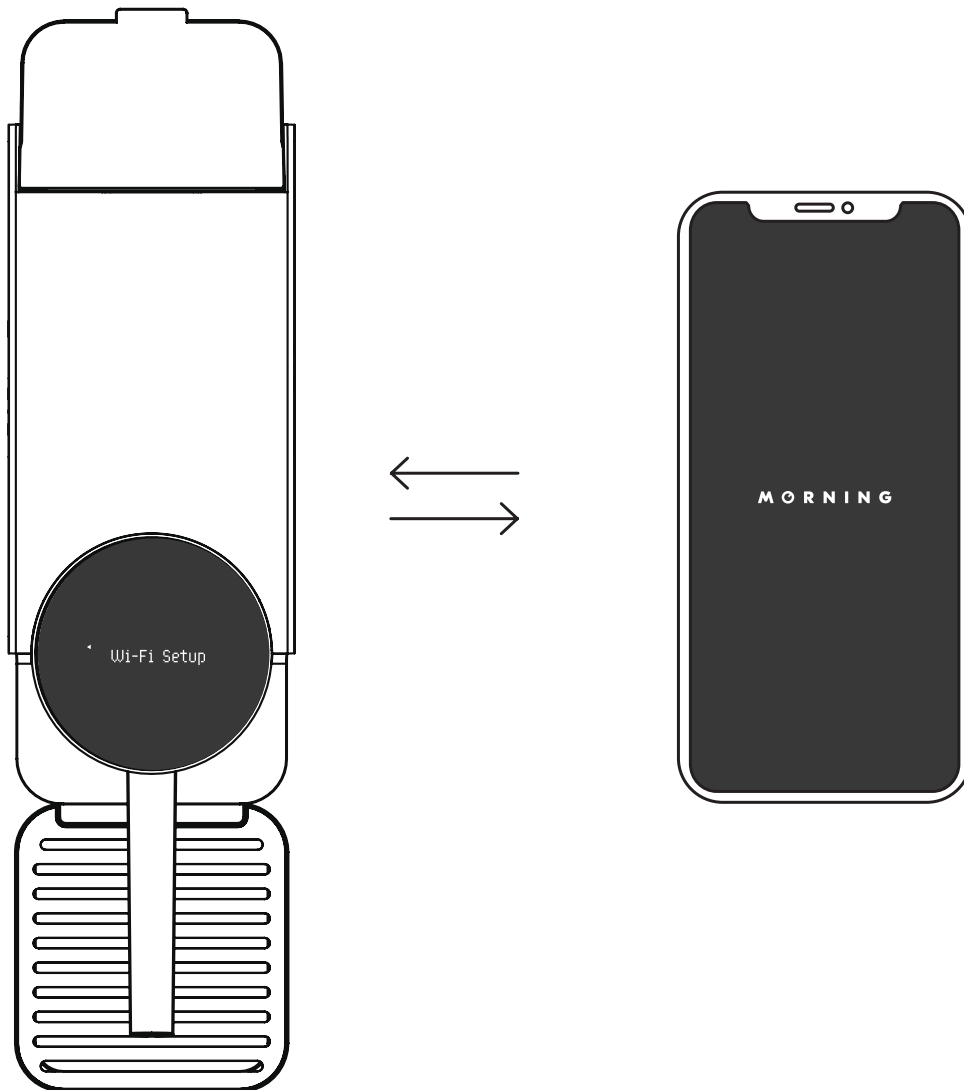

- You will need to connect the machine to a Wi-Fi source with an active internet connection.
- Turn on Bluetooth on your device before proceeding.

STEPS ON HOW TO PAIR



1. Download the Morning App from the Apple App Store or the Google Play Store. Search for "DrinkMorning".
2. Ensure that Bluetooth is switched on, then launch the Morning App.
3. On your Morning Dream, enter Settings by holding down both the BACK and CONFIRM buttons for 3 seconds.
4. In Settings, select "Set Up Wi-Fi" using the slider and press the CONFIRM button.
5. The Morning Dream will display "Configure On App".
6. Back on the Morning App, navigate to the machine icon on the top left of the screen.
7. Click on the New Machine button.
8. When you see your machine on screen, select Connect.
9. Select "Refresh" if the Morning Dream does not appear.
10. Select your local Wi-Fi SSID and enter the password. Press "Connect".
11. Upon successful connection, your machine should display "Success".
12. You may now exit the connection page on the app.

ECO MODE

The Morning Dream has an Eco Mode for energy saving purposes.

- By default, the Morning Dream will automatically switch to Eco Mode after the touchscreen is left idle for more than 1 minute.
- To wake the Morning Dream up, touch any of the on-screen buttons.
- To adjust the Eco Mode settings, on the Morning Dream, navigate to “Settings” followed by “Eco Mode”.

CLEANING AND MAINTENANCE

WARNING: IMPORTANT SAFETY INFORMATION

- **Water Exposure:** Under no circumstances should the Morning Dream or any of its components be submerged in water. This can lead to electrical hazards and damage to the machine.
- **Power Safety:** Always disconnect the Morning Dream from the power source before initiating any cleaning procedures. This precaution is necessary to prevent electric shock or damage to the machine.
- **Cleaning Agents:** Refrain from using any harsh or solvent-based cleaning agents when cleaning the Morning Dream. Such substances can cause irreparable damage to the surface and internal components.
- **Abrasive Tools:** Avoid the use of sharp objects, stiff brushes, or any kind of abrasive material that could scratch or damage the surface of the Morning Dream.
- **Dishwasher Usage:** The Morning Dream is not designed to be dishwasher-safe. Placing the machine or any of its parts in a dishwasher could result in damage and is strictly prohibited.

DAILY CLEANING

We recommend purging the Morning Dream and wiping the steam wand and tip after each use.

1. Perform a purge and wipe the steam wand and tip.
2. Remove the drip tray and rinse.
3. Remove the water tank and rinse.
4. Dry all the parts with a fresh and clean towel, cloth or paper towel.

DEEP CLEANING (ONCE A MONTH)

We recommend cleaning the Morning Dream once a month with cleaning products.

1. Prepare a milk jug filled with fresh filtered water.
2. Pour a sachet of milk cleaner into a pitcher filled full with water. Mix well into a solution.
3. Submerge the steam wand in the solution up to the halfway mark.
4. Activate any preset mode (whole milk, low fat milk or alternative milk) and let the solution heat to 50 to 60 degrees celsius. Ensure that the infrared laser is pointed directly at the solution for an accurate temperature measurement.
5. Leave the steam wand submerged in the solution for 30 to 45 minutes.
6. Remove the steam wand from the solution and purge the Morning Dream at least 3 times.

DESCALING (ONCE A MONTH)

We recommend descaling the Morning Dream once a month with descaling products.

1. Fill the water tank with fresh, filtered water, to the 0.5L mark
2. Add 1 sachet of descaling powder into the water tank.
3. Remove the drip tray and place a large container under the steam wand.
4. Navigate to “Settings” followed by “Maintenance” on the Morning Dream.
5. Run “Stage 1 Maintenance” and follow the on-screen instructions.
6. Run “Stage 2 Maintenance” and follow the on-screen instructions.
7. During the descaling process, you will be required to refill the water tank. At this point, you may refill the water tank to the full amount.
8. The Morning Dream will prompt you when descaling is complete.
9. Should you need to pause the descaling process to empty the large container, press the BACK button at any time.

TROUBLESHOOTING

PROBLEM	POSSIBLE CAUSE	SOLUTION
The machine does not turn on.	Power switch is off.	Make sure your wall power switch is turned on.
	Power supply damaged.	Ensure the machine is plugged in. Check the power outlet and inspect the power cord for damage.
Milk does not steam properly.	Incorrect preset mode selection.	Use the machine's preset mode for low fat or alternative milks. If the issue persists, try using the manual mode.
	Steam wand blocked.	The steam wand is likely clogged by milk residue. Remove the steam tip and clean it with a fine haired brush.
Inconsistent quality of foam.	Incorrect position of steam wand during steaming.	Adjust the steam wand's position to just below the milk surface.
	Steam wand not purged.	Purge the steam wand before and after use to eliminate milk residue.
	Steam wand or nozzle dirty.	Clean the steam wand and nozzle regularly with a fine haired brush to prevent residue buildup.
The machine is making an unusual noise.	Low water level.	Ensure the water tank is properly filled.
	Trapped air in the machine.	Purge the machine to remove any trapped air.
	Debris in the machine.	Check for and remove any debris around the steam wand and water intake.
The machine is leaking water.	Over filling the water tank.	Avoid overfilling the water tank.
	Improper fitment of water tank.	Make sure all parts are correctly assembled and secured.
Abnormal Flow Rate error message.	Flow meter issue or empty water tank.	Check and refill the water tank, and inspect the flow meter for malfunctions.
Pump Block error message.	Pump malfunction, blocked water inlet or solenoid valve malfunction.	Check for pump issues, clean any blockages in the water inlet.
Heating Failed error message.	Boiler malfunction.	Check for electrical issues or scale buildup in the boiler. Professional servicing may be required.
Machine Overheat error message.	PCB temperature too high.	Turn off the machine to cool down. Check the cooling system or internal components for issues.
The temperature display does not rise normally during steaming.	Water droplets inside the infrared temperature sensor opening.	Use an air blower, aim the nozzle at the infrared temperature sensor opening. Blow air into the opening 3-5 times.

TECHNICAL SPECIFICATIONS

Size and weight	370mm (L) x 100mm (W) x 340mm (H), 4.5kg
Water tank capacity	600ml
OLED screen size	2.42 inches
OLED resolution	128 x 64 pixels
Buttons	2 capacitive buttons and a touch slider interface 50mm x 8 mm
Maximum steam pressure	15 bar
Selectable power setting	50 to 100%
Selectable temperature	40 to 75°C ($\pm 2^{\circ}\text{C}$)
Electrical specifications	AC100V 50-60Hz 1400W, max 15A AC120V 50-60Hz 1700W, max 15A AC230V 50-60Hz 2300W, max 11A
Connectivity	Wi-Fi and Bluetooth
Software requirements	iOS (version 10.0 or later) Android (version 5.0 or later)

RESETTING THE MACHINE

When you reset your Morning Dream all Wifi connection settings are deleted.

To perform a reset:

1. Navigate to “Settings” on the Morning Dream.
2. Select “Machine Settings Reset”.
3. Press CONFIRM.

WARRANTY INFORMATION

Morning warrants this product against defects in materials and workmanship for a period of one year (two years for EU countries) from the date of purchase. Official receipts shall serve as proof of purchase.

During this period, Morning will either repair or replace, at its discretion, any defective product at no charge to the owner. Replacement products or repaired parts will be guaranteed for only the unexpired portion of the original warranty or six months, whichever is greater.

This limited warranty does not apply to any defect resulting from accidental misuse, or any other reason beyond Morning's reasonable control, including but not limited to: normal wear and tear, negligence or failure to follow the product instructions, improper or inadequate maintenance, calcium deposits or descaling, connection to improper power supply, unauthorised product modification or repair, use for commercial purposes, fire, lightning, flood or other external causes.

This warranty is valid only in the country of purchase or in such other countries where Morning sells or services the product.

This limited warranty shall be the full extent of Morning's liability however caused. Except to the extent allowed by applicable law, the terms of this limited warranty do not exclude, restrict or modify the mandatory statutory rights applicable to the sale of this product and are in addition to those rights.

If you believe your product is defective, please reach out to us at hello@drinkmorning.com for instructions on where to send or bring it for repair.

DRINKMORNING.COM